

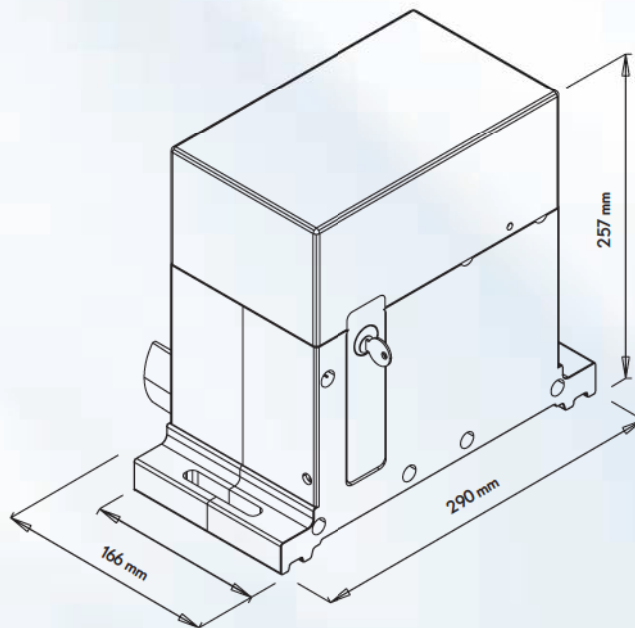

## CHARACTERISTIC

Gear-motor up to 1000 - 1600 kg totally lubricated in bath of oil. Oil level at sight facility, mechanical limit switch, unlocking device with personalized key. Speed 12 m/min minute (ref. to EN norms) with mechanical friction in oil bath.



## TECHNICAL FEATURES

	AG 2000 1000 kg	AG 2000 1600 kg	AG 2000 1600 kg Threephase
MOTOR POWER SUPPLY	230 Vac	230 Vac	380 Vac
MAX LEAF WEIGHT	1000 Kg	1600 Kg	1600 Kg
MOTOR RPM	1400 rpm	1400 rpm	1400 rpm
PINION	M4-Z16	M4-Z16	M4-Z16
AVERAGE CONSUMPTION	1,7 A	18 A	1,5 A
MOTOR RATING	330 W	360 W	500 W
CONDENSER	16 uF	16 uF	-
ACTUATOR WEIGHT	13 Kg	13 Kg	13 Kg
NOISE LEVEL	< 30 dBA	< 30 dBA	< 30 dBA
WORKING TEMPERATURE	-20/+55° C	-20/+55° C	-20/+55° C
THERMAL CUT OUT	140° C	140° C	140° C
LIMIT SWITCH	Electric	Electric	Electric
FREQUENCY OF USE	50%	50%	80%
SPEED (UNLOAD WEIGHT)	10 m/min	10 m/min	10 m/min
IP/ RATING	IP44	IP44	IP44